

**Contents**

|  |    |
|--|----|
| Introduction .....   | 2  |
| Introducing Modeling Polynomials .....                             | 3  |
| Modeling Polynomials Worksheets .....                              | 5  |
| Modeling Polynomials Extra Practice .....                          | 9  |
| Introducing the Zero Principle .....                               | 10 |
| The Zero Principle Worksheets .....                                | 12 |
| The Zero Principle Extra Practice .....                            | 16 |
| Introducing Adding & Subtracting Polynomials .....                 | 17 |
| Adding & Subtracting Polynomials Worksheets .....                  | 19 |
| Adding & Subtracting Polynomials Extra Practice .....              | 23 |
| Introducing Multiplying Polynomials When All Terms Are Positive. . | 24 |
| Product Mat .....  | 26 |
| Multiplying Polynomials Worksheets .....                           | 27 |
| Multiplying Polynomials Extra Practice .....                       | 30 |
| Introducing Dividing Trinomials .....                              | 31 |
| Dividing Trinomials Worksheets .....                               | 33 |
| Dividing Trinomials Extra Practice .....                           | 36 |
| Mixed Review Practice Worksheets .....                             | 37 |
| Answer Key .....   | 41 |

## Introduction

If you are a math teacher attempting to teach beginning algebraic concepts, this book is for you. Educators have always embraced the idea of hands-on learning. In early mathematics, we give children all types of manipulatives to help them better understand basic math functions. Counters, rods, blocks, and play money are just a few examples.

It seems, however, that as students get older, we tend to shy away from hands-on experiences and expect students to simply visualize a concept through the use of illustrations found within math texts.

Algebra Tiles™ are not meant to replace math texts or traditional math instruction. Instead, Algebra Tiles provide concrete models of variables and integers that enable students to explore and better comprehend basic algebraic concepts. The lessons and worksheets in this book are designed to be used *with* your Algebra Tiles. In each of the five units you will find the following components:

- Introducing the Concept: instructions for introducing the lesson to students
- Practicing the Concept: problems and ideas for practicing the concept as a group
- Worksheets for Review (four worksheets per concept): blackline masters to copy for each student, worksheets progress in difficulty
- Extra Practice Page (one worksheet per concept): a page of problems for teachers to use as remediation, enrichment, warm-up, homework, or extra practice for students who complete work before others

Note: At the end of the book you'll find mixed practice pages that combine all the skills taught as well as answers for each of the worksheet pages.

Be sure not to confuse Algebra Tiles with tools such as the abacus or calculator. The tiles do not solve problems for students; they serve as models to bridge the gap between a concept and the symbols used to record it algebraically.

Note: To teach the lessons described in this book, it would be helpful if you, the teacher, had a set of overhead Algebra Tiles and each student or pair of students had their own set of Algebra Tiles to use at their desks. Some problems may require more tiles than are provided in a single Algebra Tiles set. In these cases, encourage students to draw the tiles or combine Algebra Tile sets with other students or groups. (This affects pages 12, 15, 16, 18, 19, 20, 21, 22, 23, 36, 37, 38 and 40.)

In the Algebra Tiles student set, one side of each tile is red, representing the additive inverse. The shaded tile shapes in this workbook represent the red sides, or additive inverses, of the students' tiles.

## Introducing Modeling Polynomials

Begin by explaining that in algebra, a variable, such as  $x$  or  $y$ , is used to represent an unknown number. This variable usually represents a number.

Have students place a large square tile in front of them with the blue side showing, and tell them that if  $x$  represents the length of one side of the tile, then the area of the blue tile could be represented as  $x^2$ .

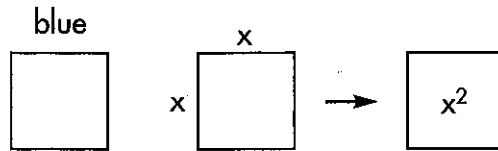

Continue this line of teaching with both the small yellow square and the green rectangle.

Tell the students that if  $y$  represents the length of the side of the small yellow square tile, then  $y^2$  would represent its area.

It would then follow that the area of the small green rectangular tile could be represented by  $xy$ , since one of its dimensions is  $x$  and the other is  $y$ .

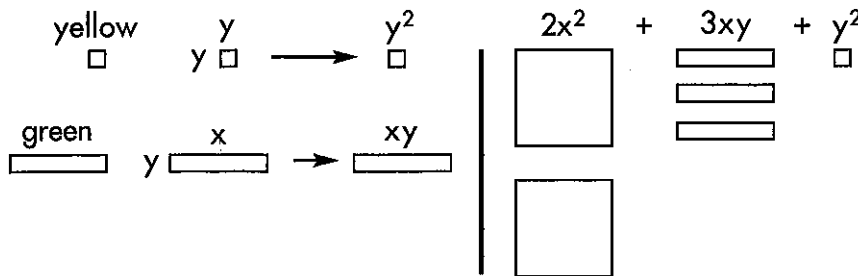

Remind the students that unlike Base Ten Blocks or other math manipulatives they may have used in the past, Algebra Tiles™ are not proportionate. One variable is not necessarily a multiple of the other—an  $x^2$  tile cannot be exactly covered by  $xy$  tiles and an  $xy$  tile cannot be covered by  $y^2$  tiles.

This is also a good time to remind students that the Algebra Tiles have a different color on each side. The faces represent a quantity and its additive inverse. The shaded tile shapes in this workbook represent the red sides, or additive inverses, of the actual tiles.

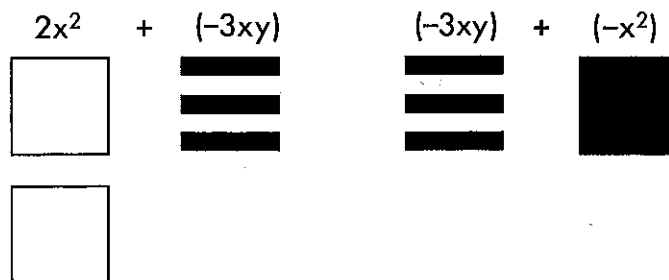

## Practicing the Concept

Show the following examples of modeling polynomials:

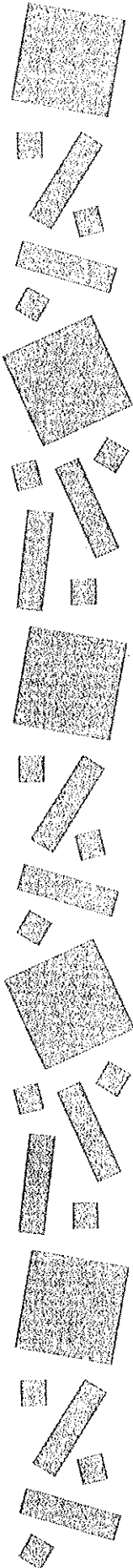

| Polynomial        | Model |  |  |  |
|-------------------|-------|--|--|--|
| $4x^2$            |       |  |  |  |
| $3xy$             |       |  |  |  |
| $-2xy$            |       |  |  |  |
| $x^2 - xy - 2y^2$ |       |  |  |  |

Write the polynomials listed below on the board or overhead. Ask students to use their Algebra Tiles™ to model the polynomials. Model the polynomials with a set of overhead Algebra Tiles or move about the room working with students. Continue the practice until the students are comfortable with the process.

Write these polynomials on the board:

Have students create models like those shown below:

$4xy$



$3x^2$

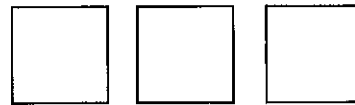

$3x^2 - xy - 3y^2$



# Modeling Polynomials Worksheet 1

Name \_\_\_\_\_

Draw a picture of a tile model for each of the following polynomials.

Let  represent  $x^2$ ,  represent  $xy$ , and  represent  $y^2$ .



| Polynomial            | Model |
|-----------------------|-------|
| 1. $2x^2 + 5xy + y^2$ |       |
| 2. $-x^2 + 2xy$       |       |
| 3. $4x^2 - 3xy + y^2$ |       |
| 4. $x^2 - 2xy - 3y^2$ |       |
| 5. $-2x^2 - 4xy$      |       |





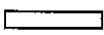

# Modeling Polynomials Worksheet 2

Name \_\_\_\_\_

Write the polynomial represented by the following tile pictures.

Let  represent  $x^2$ ,  represent  $xy$ , and  represent  $y^2$ .

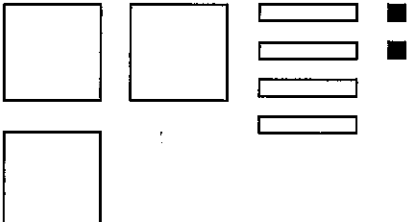

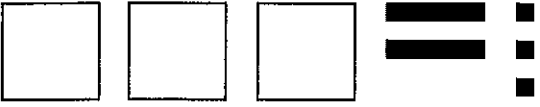



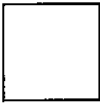
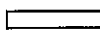

|    | Model   | Polynomial |
|----|---|------------|
| 1. |    |            |
| 2. |    |            |
| 3. |  |            |
| 4. |  |            |
| 5. |  |            |

# Modeling Polynomials Worksheet 3

Name \_\_\_\_\_

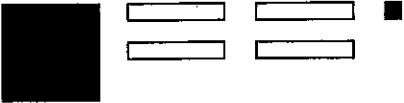
Write the polynomial represented by the following tile pictures.

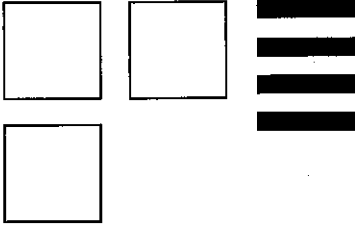
Let  represent  $x^2$ ,  represent  $xy$ , and  represent  $y^2$ .

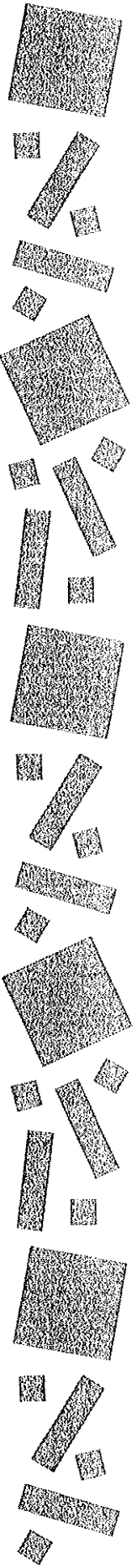

|    | Model   | Polynomial |
|----|---|------------|
| 1. |    |            |
| 2. |    |            |
| 3. |  |            |
| 4. |  |            |
| 5. |  |            |



# Modeling Polynomials Worksheet 4

Name \_\_\_\_\_

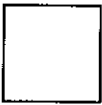
Use your Algebra Tiles™ to represent each polynomial. Then draw tile models for each.

Let  represent  $x^2$ ,  represent  $xy$ , and  represent  $y^2$ .

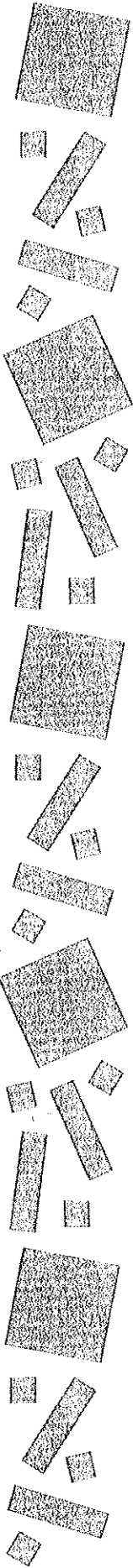



| Polynomial              | Model |
|-------------------------|-------|
| 1. $4x^2 + 2xy - 3y^2$  |       |
| 2. $-3x^2 - xy + 2y^2$  |       |
| 3. $4x^2 + 3xy - y^2$   |       |
| 4. $-2x^2 - 4xy - 3y^2$ |       |
| 5. $3x^2 - 4xy + 5y^2$  |       |



## Modeling Polynomials Extra Practice

Name \_\_\_\_\_

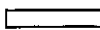
Use your Algebra Tiles™ to show the following polynomials. Then draw a tile model for each.

Let  represent  $x^2$ ,  represent  $xy$ , and  represent  $y^2$ .

| Polynomial             | Model |
|------------------------|-------|
| 1. $2x^2 + xy + y^2$   |       |
| 2. $4x^2 + y^2$        |       |
| 3. $-2xy + 3y^2$       |       |
| 4. $-4x^2 - 6xy$       |       |
| 5. $2x^2 + 3xy + 2y^2$ |       |
| 6. $-2xy + 4y^2$       |       |
| 7. $3x^2 - 3xy + y^2$  |       |
| 8. $-x^2 - y^2$        |       |

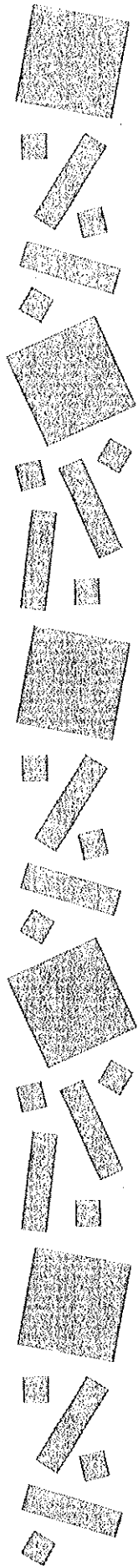

## Introducing the Zero Principle

Begin by showing students two large tile squares with opposite sides in view.



Ask students to state their similarities and differences. Point out that they do have the same dimensions and thus they represent like quantities and have the same value. But, as noted in the previous lesson, because they are the inverse of one another, they have opposite signs. One is positive and one is negative.

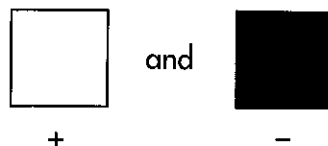

Tell students that when tiles of the exact same dimension and value are presented together yet one is positive and the other is negative, they cancel each other out and form a model of zero.

This is called the **Zero Principle**.

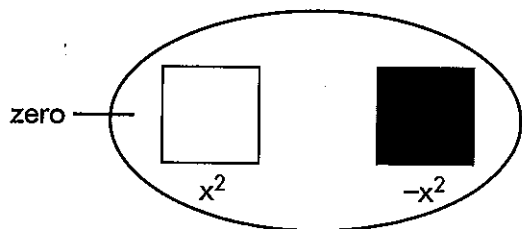

**Zero can be represented by any two like quantities with opposite signs.**

Using Algebra Tiles™, tell students that there are many ways to represent the Zero Principle.

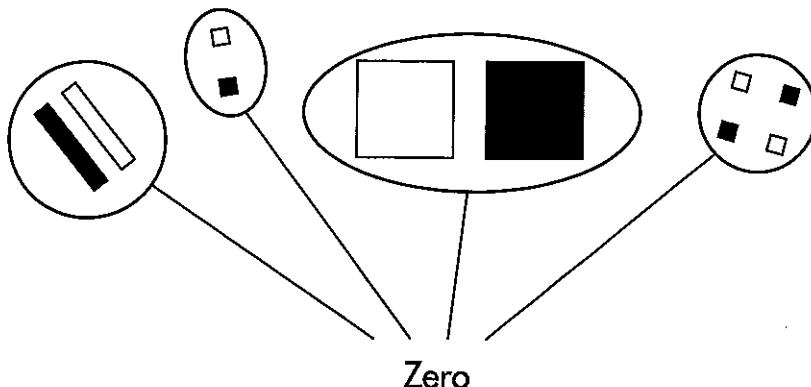

Explain that any two quantities that cancel each other out to form zero are called **additive inverses** or **opposites**. Any two tiles or groups of tiles that cancel each other out are models of additive inverses.

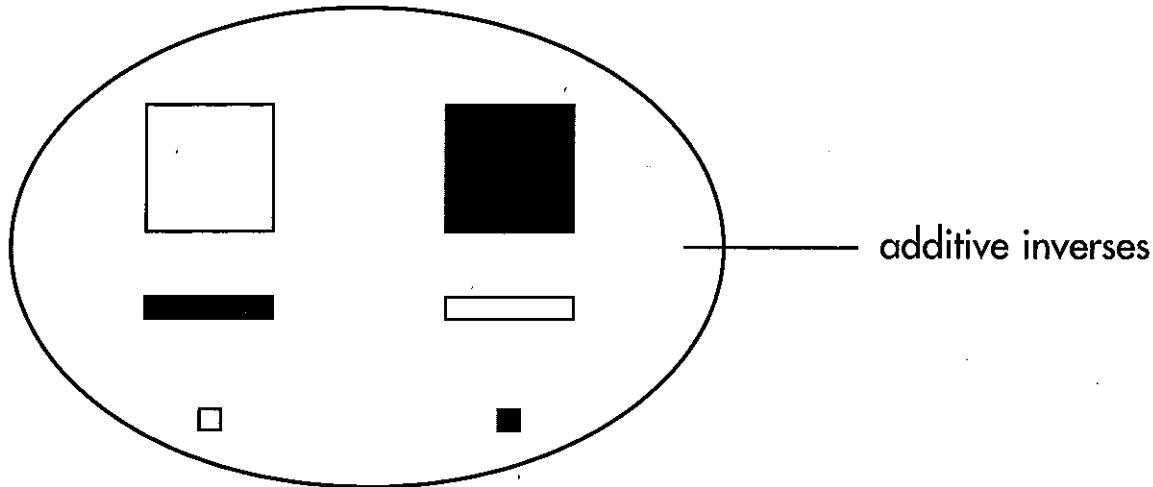

**Practicing the Concept**

Display random groups of tiles and have students identify instances where the Zero Principle can be applied. Tell students to simply move tiles that represent additive inverses to the side and only write the terms represented by the tiles that remain.

To model a polynomial such as  $x^2 - 3x + 4$ , which has a constant term, each side of one of the small square tiles can be assigned the length of 1 unit, meaning its area is 1 square unit. The larger square tile represents  $x^2$ , leaving the rectangular tile to represent  $x$ .

Tell students that  $x^2 - 3x + 4$  can then be thought of as  $x^2 + (-3x) + 4$  and modeled as appears below.



To further practice the concept, ask students to write the additive inverse of the following:

$5x + 1$        $3x^2 - 6$        $-2 + 4x$        $-4x^2 - 7$

Answers:       $-5x - 1$        $-3x^2 + 6$        $2 - 4x$        $4x^2 + 7$

The Mixed Review Practice Worksheets beginning on page 37 ask students to write the additive inverse.

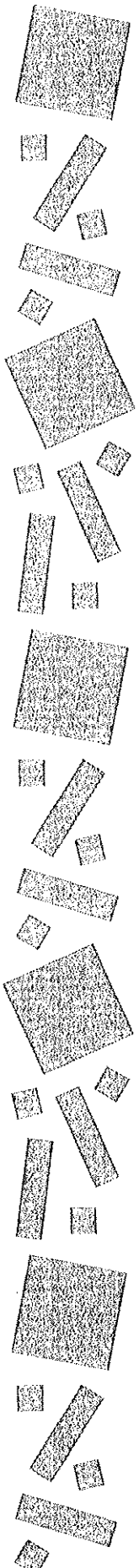

# The Zero Principle Worksheet 1

Name \_\_\_\_\_

In each problem shown below, remove or cross out the model tiles that show an additive inverse, and draw the terms represented by the remaining tiles. Use your Algebra Tiles™ to help you.

Let  represent  $x^2$ ,  represent  $x$ , and  represent 1.

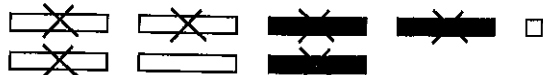
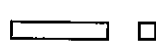
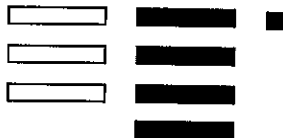
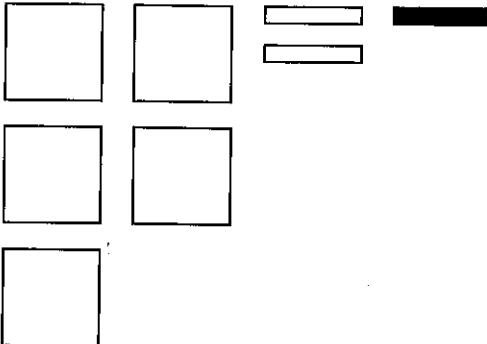
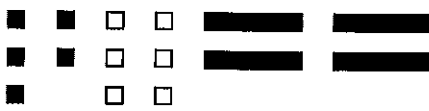
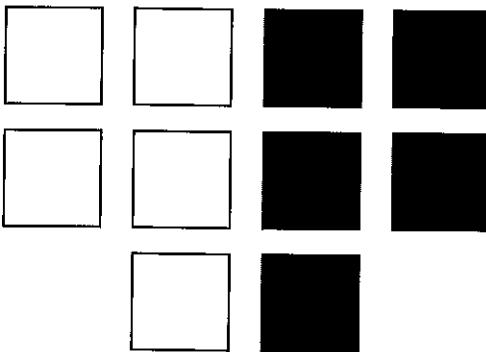

| Polynomial   | Simplified Polynomial  |
|--|--|
| Example: $4x - 3x + 1$<br>    | $x + 1$<br> |
| 1. $3x - 4x - 1$<br>          |  |
| 2. $5x^2 + 2x - x$<br>       |  |
| 3. $-5 + 6 - 4x$<br>        |  |
| 4. $2x^2 + 3x^2 - 5x^2$<br> |  |

# The Zero Principle Worksheet 2

Name \_\_\_\_\_

Write the definition of an additive inverse:

Draw three examples of an additive inverse. Use your Algebra Tiles™ to help you.

1.

2.

3.

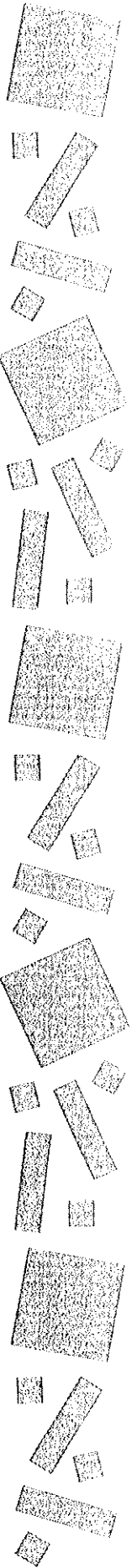

# The Zero Principle Worksheet 3

Name \_\_\_\_\_

Let  represent  $x^2$ ,  represent  $x$ , and  represent 1.

Draw pictures to represent your tile models of the following polynomials.

1.  $3x^2 - 4x + 2$

2.  $-4x - 2x + 1$

Draw the additive inverse of each of the models represented above.

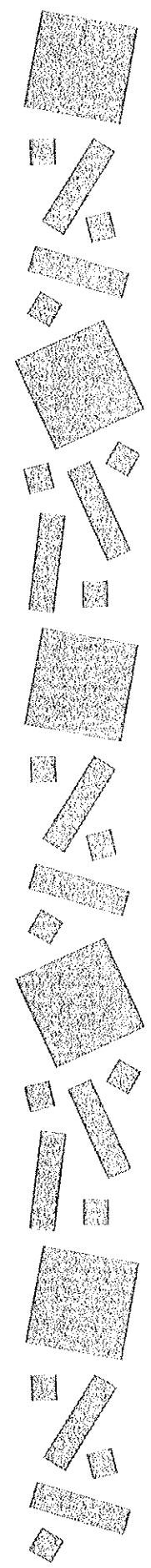

3.  $-3x^2 + 4x - 2$

4.  $4x + 2x - 1$





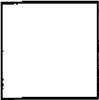
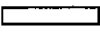

## The Zero Principle Worksheet 4

Name \_\_\_\_\_

Let  represent  $x^2$ ,  represent  $x$ , and  represent 1.

Simplify the following polynomials. Use your Algebra Tiles™ and draw tile models to help you.

| Polynomial             | Model   |
|------------------------|---|
| 1. $2x^2 + 4x^2 - x^2$ |    |
| 2. $-3x + 2x + 4 - 2$  |   |
| 3. $4x^2 - 2x + 3x$    |  |
| 4. $-5 + 6 + 4x$       |  |



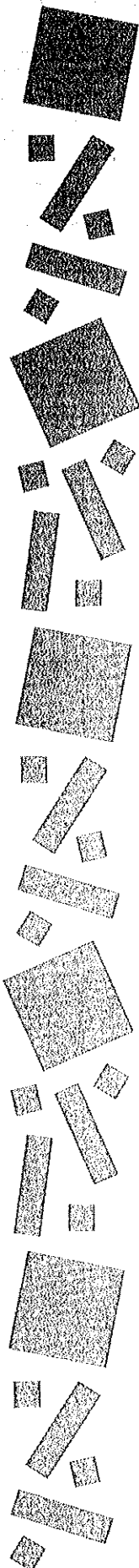

# The Zero Principle Extra Practice

Name \_\_\_\_\_

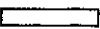

Use Algebra Tiles™ and draw tile models to help you simplify the following:

Let  represent  $x^2$ ,  represent  $x$ , and  represent 1.

1.  $4x^2 - 3x^2 + 1$

2.  $3x - 2x + 5$

3.  $2x^2 - 2x^2 + x$

4.  $x^2 - 3x^2 + 3$

5.  $-4x - 3x + 1 - 4$

6.  $3x^2 - x^2 + 4x$

7.  $6x - x + 3$

8.  $-x^2 + x^2 + 2$



9.  $6x - 2x - x$

10.  $2x^2 - x^2 + 4$



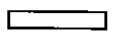

### Introducing Adding & Subtracting Polynomials

Tell students that when adding polynomials, you employ the Zero Principle wherever it's possible and then combine tiles that represent like terms.

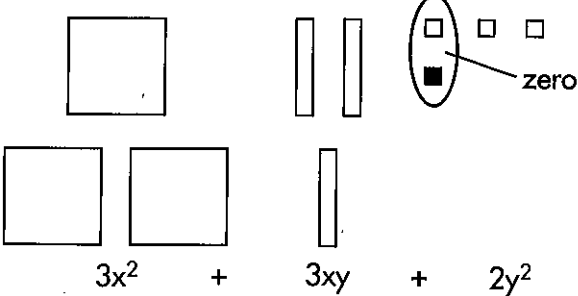
Example 1: Let  represent  $x^2$ ,  represent  $xy$ , and  represent  $y^2$ .

$$\begin{array}{r} x^2 + 2xy + 3y^2 \\ + 2x^2 + xy - y^2 \\ \hline \end{array}$$

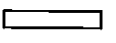

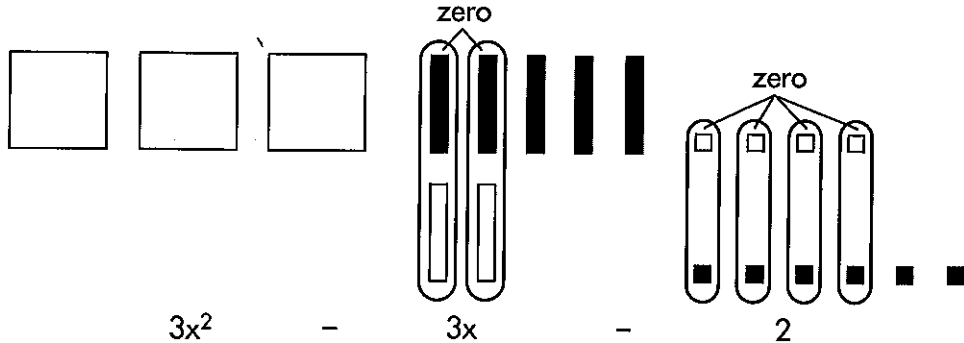

$3x^2 + 3xy + 2y^2$

Example 2: Let  represent  $x^2$ ,  represent  $x$ , and  represent 1.



$$\begin{array}{r} 3x^2 - 5x + 4 \\ + 2x - 6 \\ \hline \end{array}$$

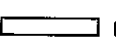

$3x^2 - 3x - 2$

Tell students that when subtracting polynomials, you "take away" tiles that represent the subtrahend or bottom portion of the equation.

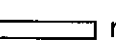
Example 1: Let  represent  $x^2$ ,  represent  $xy$ , and  represent  $y^2$ .

$$\begin{array}{r} 2x^2 - 5xy + 3y^2 \\ - (x^2 - 2xy + y^2) \\ \hline x^2 - 3xy + 2y^2 \end{array}$$

Example 2: Let  represent  $x^2$ ,  represent  $xy$ , and  represent 1.

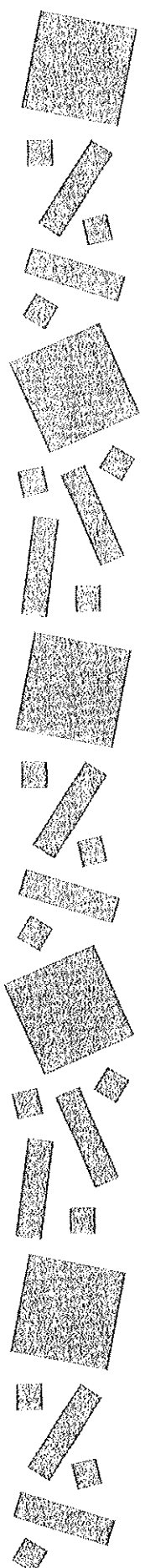
$$\begin{array}{r} 3x^2 - 7x + 4 \\ - (x^2 - 2x + 2) \\ \hline 2x^2 - 5x + 2 \end{array}$$



## Using the Zero Principle in Subtraction

Explain that the "take away" method works well when there are tiles readily available to take away. When there aren't enough of the right tiles to "take away," students can apply the zero principle and then subtract.

$$\begin{array}{r} 2x^2 - 7x + 4 \\ - (x^2 + 2x + 2) \\ \hline \end{array}$$

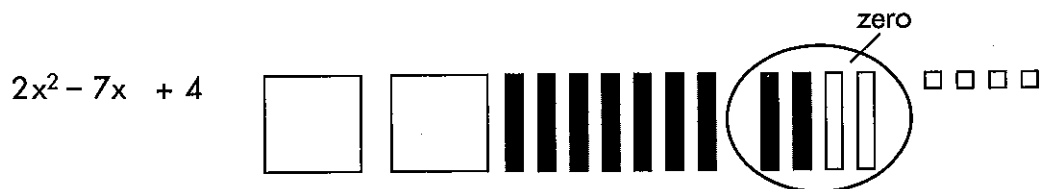
There are no  $x$  tiles to take away, only  $-x$  tiles. However, you can provide as many  $x$  tiles as you need by applying the Zero Principle. Since you need two  $x$  tiles, you can represent the problem as follows:



Now, take away the tiles that represent the subtrahend  $x^2 + 2x + 2$  and count the remaining tiles to determine the difference.



The model above shows that the subtrahend tiles have been taken away leaving  $x^2 - 9x + 2$ .

## Practicing the Concept

Post the following addition and subtraction exercises on the board. Allow students to combine tile sets and draw model tiles as they work through each problem.

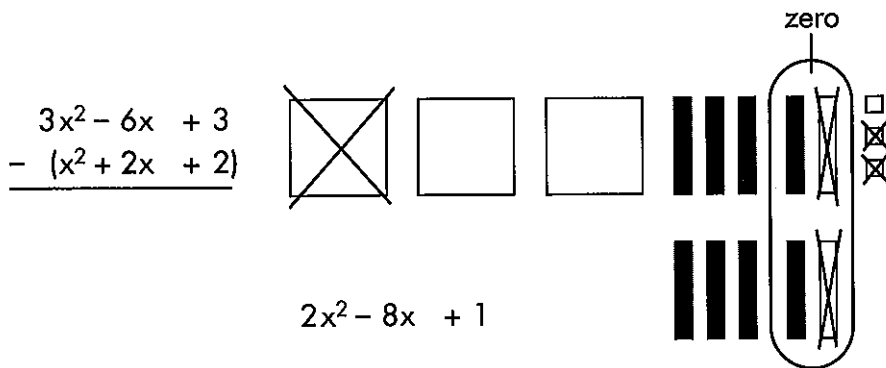

$$2x^2 - 8x + 1$$

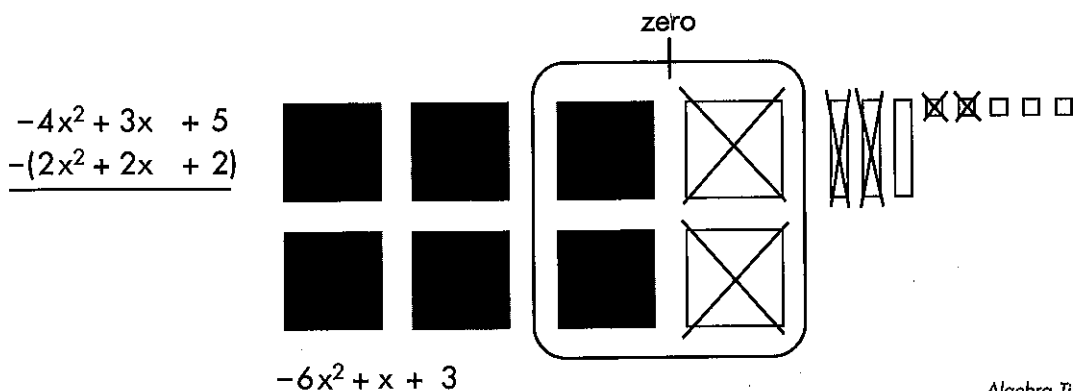





$$-6x^2 + x + 3$$

# Adding & Subtracting Polynomials Worksheet 1

Name \_\_\_\_\_

Let  represent  $x^2$ ,  represent  $x$ , and  represent 1.

Add the following polynomials. Use your Algebra Tiles™ and draw tile models to help you solve the problems. Remember to apply the Zero Principle first and then add.

| Problem  | Model   |
|--|---|
| $\begin{array}{r} 1. \quad 3x^2 - 2x + 4 \\ + (-x^2 - x - 2) \\ \hline \end{array}$  | <br> |
| $\begin{array}{r} 2. \quad 4x - 3 \\ + (-x - 2) \\ \hline \end{array}$               |    |
| $\begin{array}{r} 3. \quad 5x^2 + 6 \\ + (2x^2 - 2) \\ \hline \end{array}$           |    |
| $\begin{array}{r} 4. \quad -4x^2 - 3x - 6 \\ + (2x^2 - x + 4) \\ \hline \end{array}$ |    |

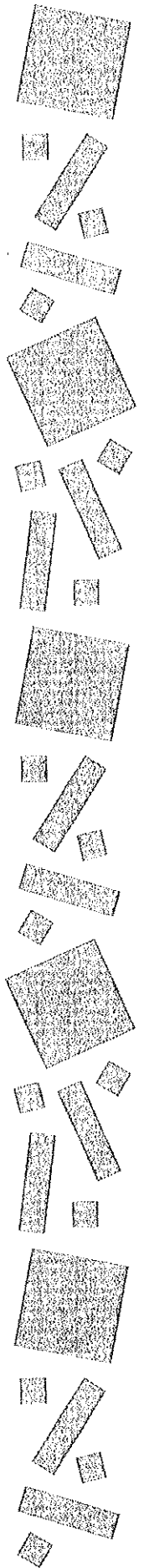

## Adding & Subtracting Polynomials Worksheet 2

Name \_\_\_\_\_

Add the following polynomials. Use your Algebra Tiles™ and draw models to help you solve the problems. Remember to apply the Zero Principle first and then add.

| Problem                                    | Model             |
|--|-------------------|
| 1. $-6x^2 - 3x + 4$<br>$+ (-2x^2 - x - 3)$ | $\longrightarrow$ |
| 2. $-2x^2 - 2x + 1$<br>$+ (-3x^2 - x - 1)$ | $\longrightarrow$ |
| 3. $3x + 4$<br>$+ (2x + 3)$                | $\longrightarrow$ |
| 4. $-5x^2 - 4$<br>$+ (-3x^2 - 2)$          | $\longrightarrow$ |



# Adding & Subtracting Polynomials Worksheet 3

Name \_\_\_\_\_

Subtract the following polynomials. Use your Algebra Tiles™ to help you complete each problem. In these problems, you can simply take away the tiles that represent the terms of the subtrahend.

| Problem   | Model |
|---|-------|
| $\begin{array}{r} 1. \quad -3x^2 - 2x + 4 \\ \quad - (x^2 + x + 2) \\ \hline \end{array}$   |       |
| $\begin{array}{r} 2. \quad 4x - 3 \\ \quad - (x + 2) \\ \hline \end{array}$                 |       |
| $\begin{array}{r} 3. \quad 4x^2 + 6 \\ \quad - (2x^2 + 2) \\ \hline \end{array}$            |       |
| $\begin{array}{r} 4. \quad -4x^2 - 3x - 6 \\ \quad + (-2x^2 + x + 4) \\ \hline \end{array}$ |       |



# Adding & Subtracting Polynomials Worksheet 4

Name \_\_\_\_\_

Subtract the following polynomials. Use your Algebra Tiles™ and draw models to help you complete each problem. You may need to apply the Zero Principle first and then count the remaining tiles.

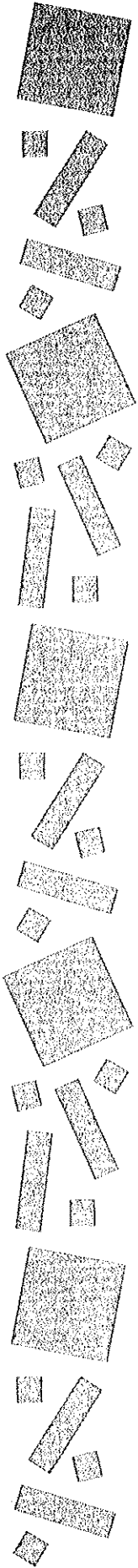

| Problem   | Model   |
|---|---|
| 1. $\begin{array}{r} -6x^2 - 3x + 4 \\ -(2x^2 + x + 3) \\ \hline \end{array}$ | <div style="border-left: 1px solid black; border-right: 1px solid black; height: 100px; margin: 0 auto; width: 80%;"></div> |
| 2. $\begin{array}{r} -2x^2 - 2x + 1 \\ -(3x^2 + x + 1) \\ \hline \end{array}$ | <div style="border-left: 1px solid black; border-right: 1px solid black; height: 100px; margin: 0 auto; width: 80%;"></div> |
| 3. $\begin{array}{r} 3x + 4 \\ -(-2x - 3) \\ \hline \end{array}$              | <div style="border-left: 1px solid black; border-right: 1px solid black; height: 100px; margin: 0 auto; width: 80%;"></div> |
| 4. $\begin{array}{r} -5x^2 - 4 \\ -(3x^2 + 2) \\ \hline \end{array}$          | <div style="border-left: 1px solid black; border-right: 1px solid black; height: 100px; margin: 0 auto; width: 80%;"></div> |

# Adding & Subtracting Polynomials Extra Practice

Name \_\_\_\_\_

Use Algebra Tiles™ and draw models to simplify the following:

Let  represent  $x^2$ ,  represent  $x$ , and  represent 1.

$$\begin{array}{r} 1. \quad 5x^2 + 2x + 1 \\ + (x^2 - x + 4) \\ \hline \end{array}$$

$$\begin{array}{r} 2. \quad 5x^2 + 2x - 1 \\ - (x^2 - x + 4) \\ \hline \end{array}$$

$$\begin{array}{r} 3. \quad 6x^2 - 3x - 1 \\ + (x^2 + 2x + 1) \\ \hline \end{array}$$

$$\begin{array}{r} 4. \quad 6x^2 - 3x - 1 \\ - (-x^2 - 2x - 1) \\ \hline \end{array}$$

$$\begin{array}{r} 5. \quad 2x^2 + 2x + 2 \\ + (-x^2 + 3x - 4) \\ \hline \end{array}$$

$$\begin{array}{r} 6. \quad 2x^2 + 2x + 2 \\ - (-x^2 + 3x - 4) \\ \hline \end{array}$$

$$\begin{array}{r} 7. \quad x^2 - x - 3 \\ + (3x^2 + 2x - 6) \\ \hline \end{array}$$

$$\begin{array}{r} 8. \quad x^2 - x - 3 \\ - (-3x^2 + 2x - 6) \\ \hline \end{array}$$

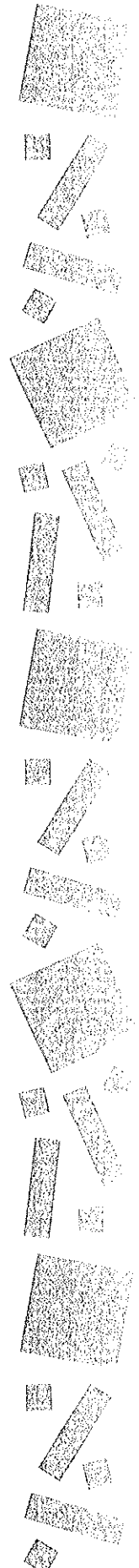

## Introducing Multiplying Polynomials When All Terms Are Positive

Note: Each student should have a Product Mat to use while learning to multiply and divide polynomials. The Product Mat (blackline on page 26) is an organizational tool that allows students to develop rectangles by their length and width. While this task can be accomplished without a Product Mat, students may have a more difficult time deciding which tiles are being used.

Using tiles to multiply polynomials builds on the basic concept of multiplication. The tiles' dimensions are identified as  $x$  and  $y$  and represent the quantity  $xy$ , which is the area of the tile.

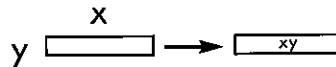

Thus, the quantity represented by a rectangular array of tiles represents the area of the array. Model the following array with the students. Note how the array demonstrates the Distributive Property of Multiplication.

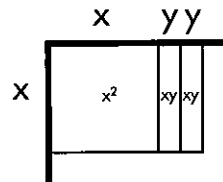

Dimensions  $\rightarrow x(x + 2y) = x^2 + 2xy = \text{Total Area}$

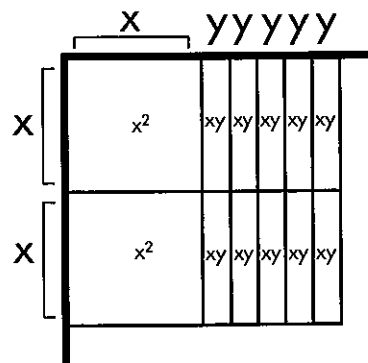

To multiply  $2x$  by  $(x + 5y)$ , have the large square tile represent  $x^2$  and the small square tile represent  $y^2$ . The first dimension,  $2x$ , is shown on the vertical axis of the Product Mat. The second dimension,  $x + 5y$ , is shown on the horizontal axis of the Product Mat. When the dimensions are multiplied, they form the area, which is represented inside the Product Mat. For example, the area of  $2x(x+5y) = 2x^2 + 10xy$ .



Have students use their Product Mats to create an array of tiles that represent the dimensions. By counting  $x^2$  tiles and  $xy$  tiles in the array, you can see that  $2x(x + 5y) = 2x^2 + 10xy$ .



Create another example for the product  $(x + 2)(x + 3)$ .

Let  represent  $x^2$ ,  represent  $x$ , and  represent 1.

Use your Product Mat to form the rectangular array.

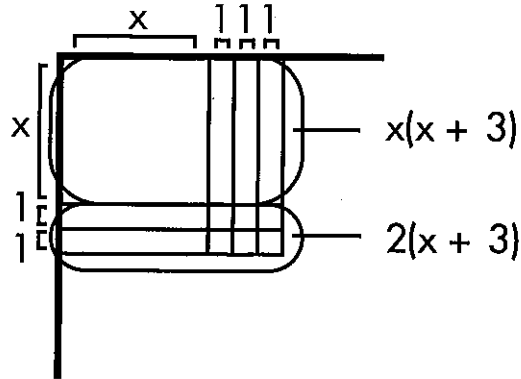

The rectangle formed is equal to  $x^2 + 5x + 6$ .

Note that the Distributive Property is used twice. Also, notice how the model illustrates traditional multiplication.

**Practicing the Concept**

Ask students to use their Algebra Tiles™ to model the following:

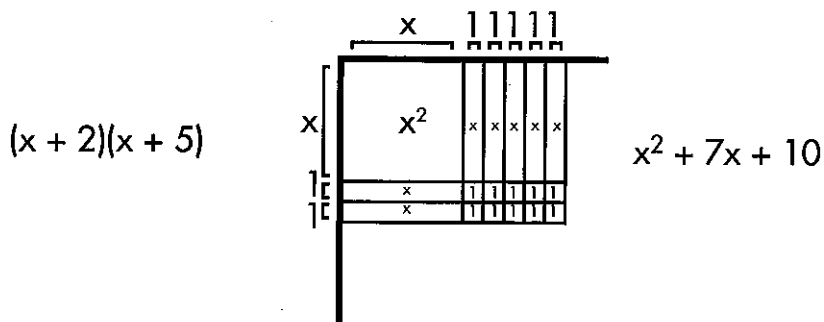
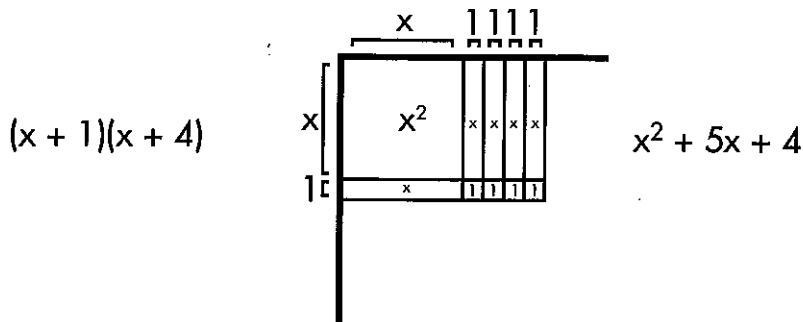

Product Mat

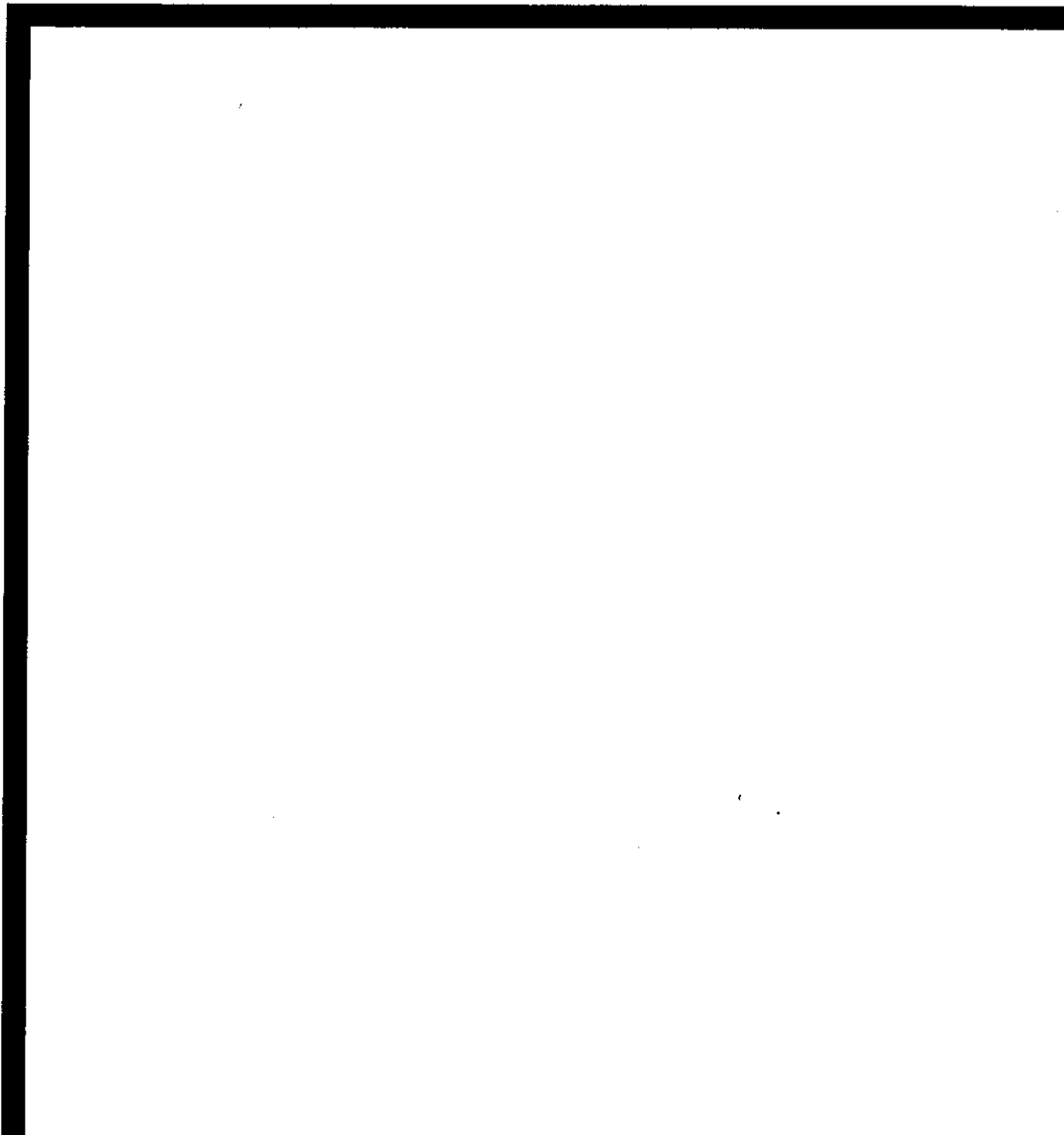
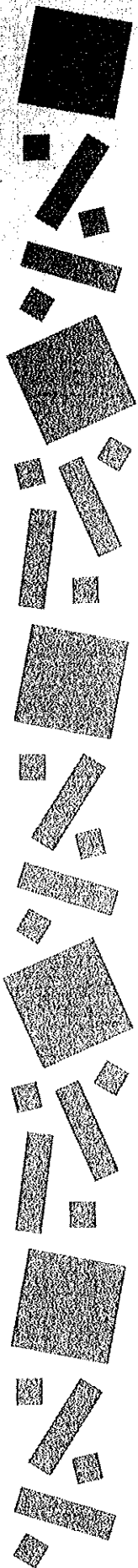

# Multiplying Polynomials Worksheet 1

Name \_\_\_\_\_

Use the model given to derive the length, width, and area of the rectangle.

Let  represent  $x^2$ ,  represent  $x$ , and  represent 1.

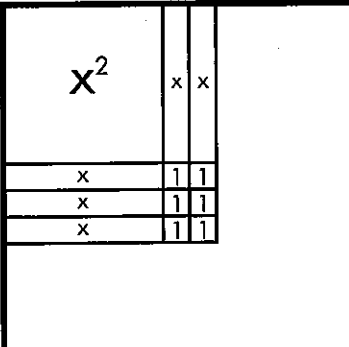
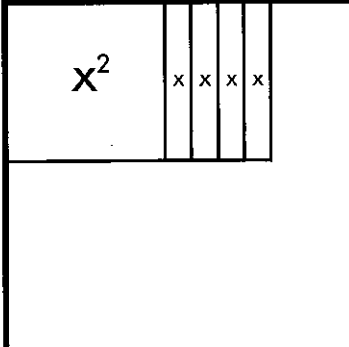
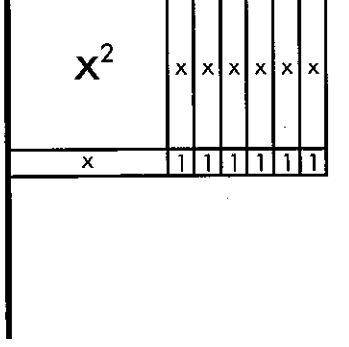

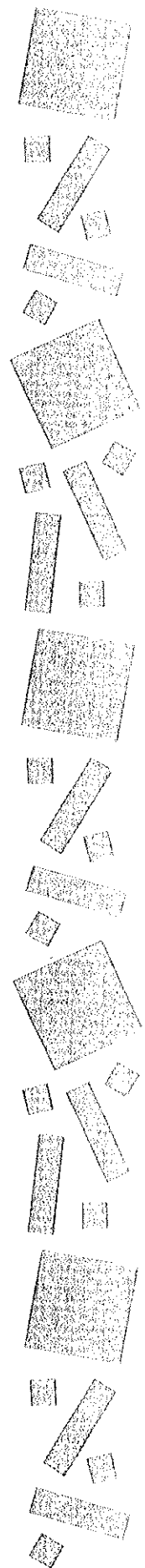
| Polynomial         | Model  |
|--------------------|--|
| 1. ( ) ( ) = _____ |    |
| 2. ( ) ( ) = _____ |  |
| 3. ( ) ( ) = _____ |  |



## Multiplying Polynomials Worksheet 2

Name \_\_\_\_\_

Multiply the polynomials listed below. Use your Algebra Tiles™ and Product Mat to create models. Draw a model for each problem.

Let  represent  $x^2$ ,  represent  $x$ , and  represent 1.





| Polynomial          | Model |
|---------------------|-------|
| 1. $x(x + 1)$       |       |
| 2. $(x + 1)(x + 3)$ |       |
| 3. $(x + 2)(x + 2)$ |       |

# Multiplying Polynomials Worksheet 3

Name \_\_\_\_\_

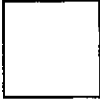
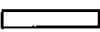
Multiply the polynomials listed below. Use your Algebra Tiles™ and Product Mat to create models. Draw a model for each problem.

Let  represent  $x^2$ ,  represent  $xy$ , and  represent  $y^2$ .

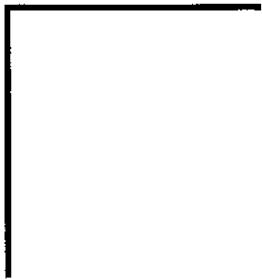
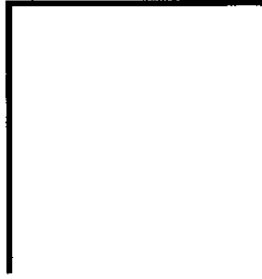
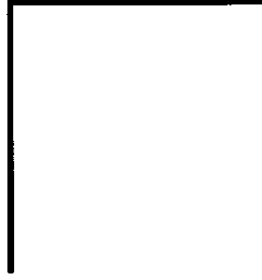
| Polynomial           | Model   |
|----------------------|---|
| 1. $(x + 2y)(x + y)$ |    |
| 2. $3x(x + y)$       |  |
| 3. $x(3x+2y)$        |  |



**Multiplying Polynomials Extra Practice**

Name \_\_\_\_\_

Multiply.

1.  $x(x + 4)$

2.  $(x + 1)(x + 5)$

3.  $(x + 2)(x + 4)$

4.  $x(2x + 5)$

5.  $(x + 1)(2x + 2)$

6.  $(2x + 3)(x + 2)$

7.  $(3x + 1)(x + 1)$

8.  $(2x + 2)(x + 1)$

9.  $(x + 3)(3x + 4)$

10.  $(2x + 5)(x + 2)$

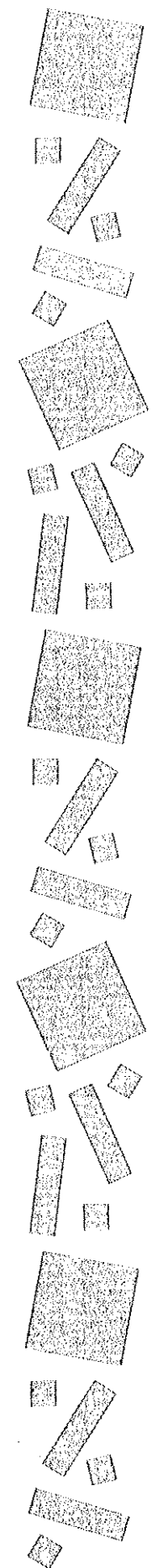

## Introducing Dividing Trinomials

Note: Each student should have a Product Mat to use while learning to multiply and divide polynomials. The Product Mat (blackline on page 26) is an organizational tool that allows students to develop rectangles by their length and width. While this task can be accomplished without a Product Mat, students may have a more difficult time deciding which tiles to use.

In division, the area of the product rectangle and one of its dimensions are given, and you must determine the other dimension.

To model  $(x^2 + 6x + 8) \div (x + 4)$ , you must arrange six  $x$  tiles and eight  $1$  tiles in a rectangular array that has  $(x + 4)$  as one of its dimensions.

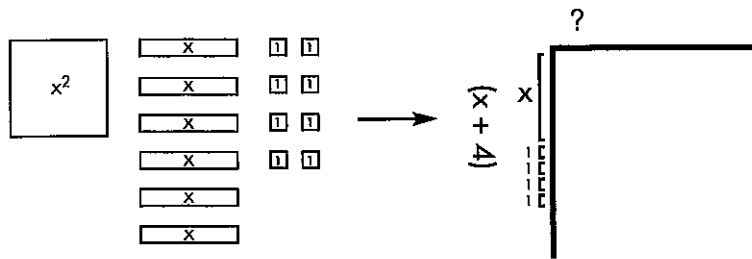

From your experience with modeling multiplication, you saw that a rectangular array can be formed by placing the  $x^2$  tile at the upper left corner of the array, the  $1$  tiles at the lower right and the  $x$  tiles at the lower left and upper right.

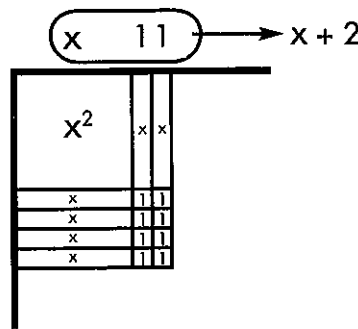

Thus,  $(x^2 + 6x + 8) \div (x + 4) = x + 2$ .

### Practicing the Concept

Ask students to use their Algebra Tiles™ to model the following:

$(x^2 + 7x + 12) \div (x + 3) = \underline{\hspace{2cm}}$

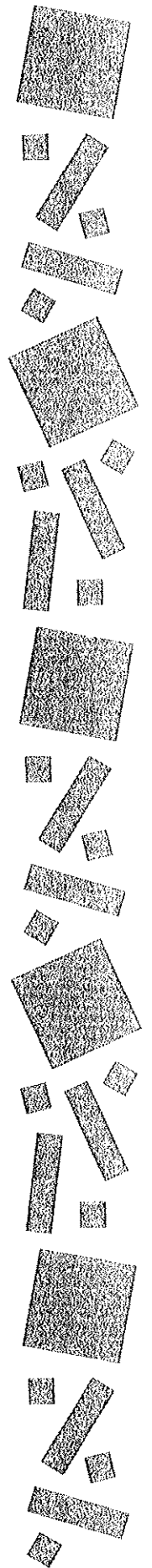
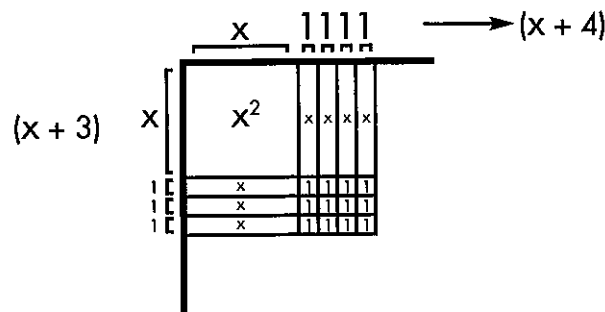

# Dividing Trinomials

Continue the lesson by switching around the operation. Ask students to use their Algebra Tiles™ to help them determine the length and width if given the area.

Example: From the area given, find the length and width of this rectangle.

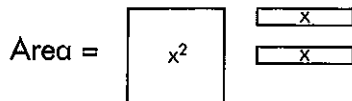

Show that the length and width can be portrayed as follows:

$x(x + 2)$  or  $(x + 2)x$

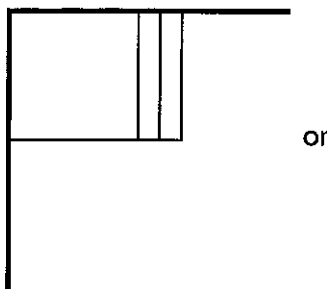

or

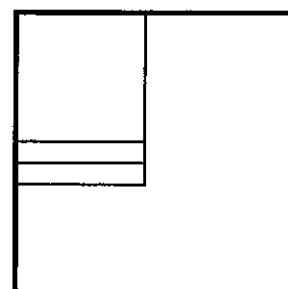

## Practicing the Concept

Display the following tiles and ask students to derive the length and width.

**x tiles**



**x<sup>2</sup> tile**

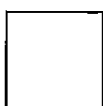

**1 tiles**

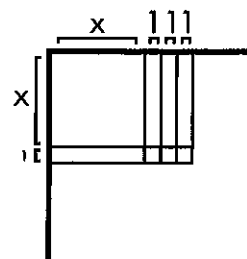

Area =  $4x$  +  $x^2$  +  $3$

Dimensions =  $(x + 3)(x + 1)$



# Dividing Trinomials Worksheet 1

Name \_\_\_\_\_

Use the model and your Algebra Tiles™ to determine each rectangle's length and width.

Let  represent  $x^2$ ,  represent  $x$ , and  represent 1.

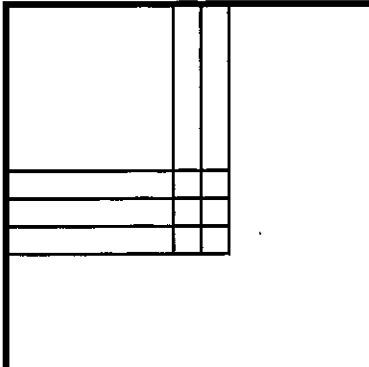
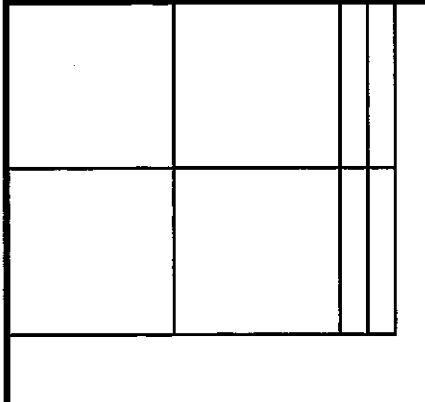
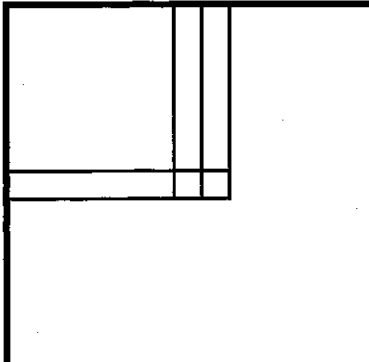
| Dimensions            | area   |
|-----------------------|--|
| 1. ( _____ )( _____ ) |     |
| 2. ( _____ )( _____ ) |  |
| 3. ( _____ )( _____ ) |   |



# Dividing Trinomials Worksheet 2

Name \_\_\_\_\_

Using your Algebra Tiles™ and the model, find the missing dimension (length or width) of each rectangle.

Let  represent  $x^2$ ,  represent  $x$ , and  represent 1.



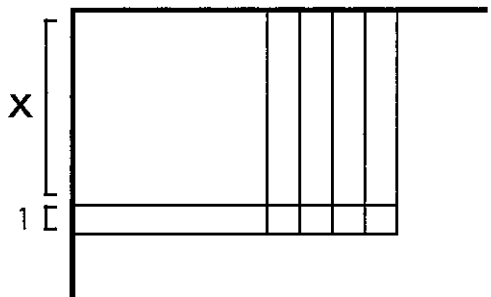
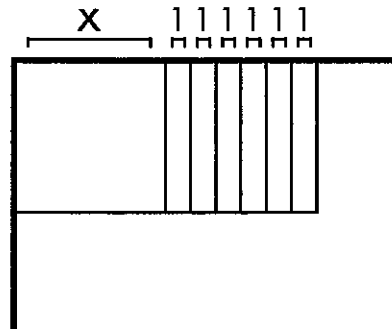
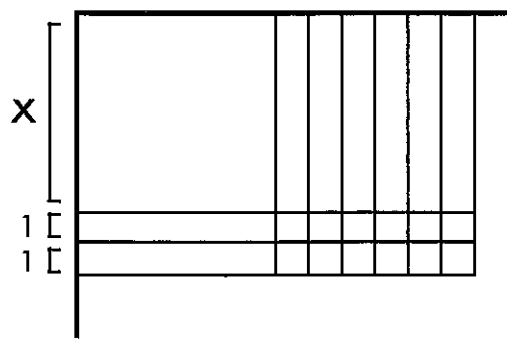

| Dimensions                             | Area   |
|--|--|
| 1. $(x + 1)(\underline{\hspace{2cm}})$ |  <p>Area = _____</p>   |
| 2. $(\underline{\hspace{2cm}})(x + 6)$ |  <p>Area = _____</p> |
| 3. $(x + 2)(\underline{\hspace{2cm}})$ |  <p>Area = _____</p> |

# Dividing Trinomials Worksheet 3

Name \_\_\_\_\_

Using your Algebra Tiles™ and Product Mat, determine the length, width, and area of the rectangles formed by the tile groupings below.

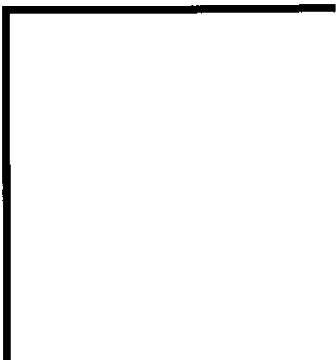
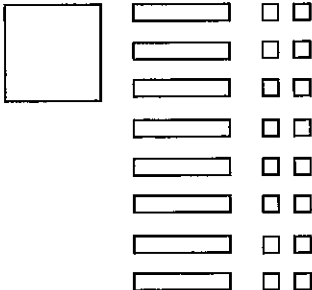
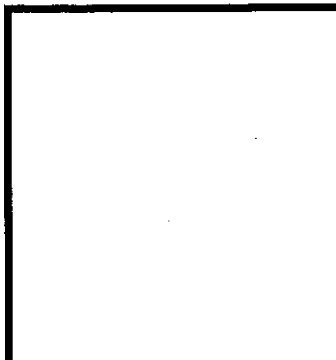
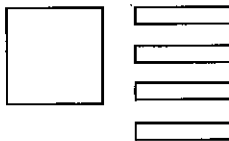
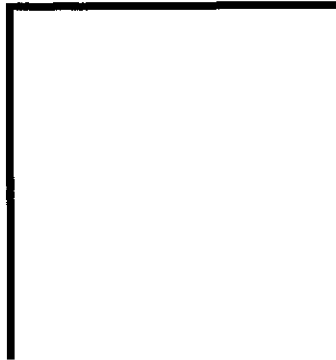
Let  represent  $x^2$ ,  represent  $x$ , and  represent 1.

| Dimensions      | Area  |   |
|-----------------|---|---|
| 1. (____)(____) |    |    |
| 2. (____)(____) |  |  |
| 3. (____)(____) |  |  |

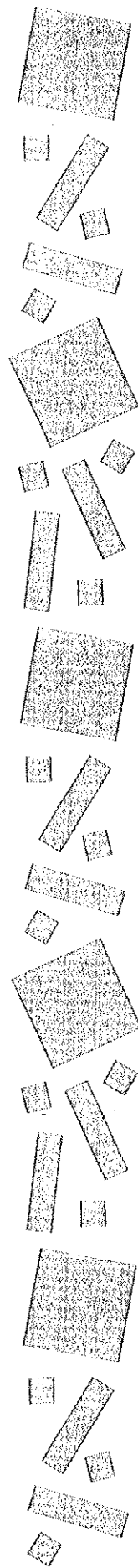

**Dividing Trinomials: Extra Practice**

Name \_\_\_\_\_

Use your Algebra Tiles™ and Product Mat and draw tile models to find the missing dimension (length or width) of the rectangle to divide these trinomials.

1.  $(x^2 + 4x) \div (x + 4) =$

2.  $(x^2 + 6x + 5) \div (x + 1) =$

3.  $(x^2 + 6x + 8) \div (x + 2) =$

4.  $(2x^2 + 5x) \div x =$

5.  $(2x^2 + 4x + 2) \div (2x + 2) =$

6.  $(2x^2 + 7x + 6) \div (x + 2) =$

7.  $(3x^2 + 4x + 1) \div (x + 1) =$

8.  $(2x^2 + 4x + 2) \div (2x + 2) =$

9.  $(3x^2 + 13x + 12) \div (x + 3) =$

10.  $(2x^2 + 9x + 10) \div (x + 2) =$

## Mixed Review Practice 1

Name \_\_\_\_\_

Use your Algebra Tiles™ and Product Mat and draw tile models to complete the following:

**Write the additive inverse.**

1.  $3x^2 - 2x + 5$

2.  $8x^2 - 2x + x$

**Add or subtract.**

3. 
$$\begin{array}{r} 5x^2 + 2x + 1 \\ + (x^2 - x + 4) \\ \hline \end{array}$$

4. 
$$\begin{array}{r} 5x^2 + 2x + 1 \\ - (x^2 + x - 4) \\ \hline \end{array}$$

**Multiply.**

5.  $(x + 3)(3x + 4) =$

6.  $(2x + 5)(x + 2) =$

**Divide.**

7.  $(x^2 + 4x) \div (x + 4) =$

8.  $(x^2 + 6x + 5) \div (x + 1) =$

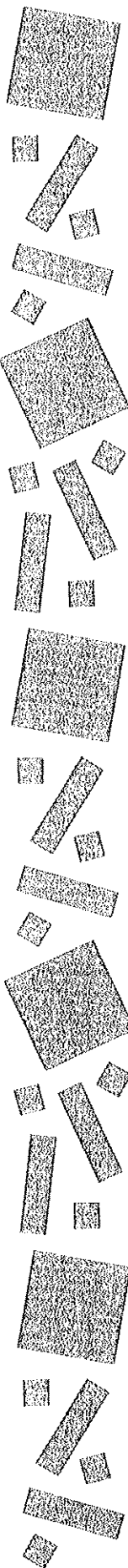

## Mixed Review Practice 2

Name \_\_\_\_\_

Use your Algebra Tiles™ and Product Mat and draw tile models to complete the following:

**Write the additive inverse.**

1.  $6x^2 - 4x^2 + 3$

2.  $-5x - 3x + 1 - 4$

**Add or subtract.**

3. 
$$\begin{array}{r} 6x^2 - 3x - 1 \\ + (x^2 + 2x + 1) \\ \hline \end{array}$$

4. 
$$\begin{array}{r} 6x^2 - 3x - 1 \\ - (-x^2 + 2x - 1) \\ \hline \end{array}$$

**Multiply.**

5.  $(3x + 1)(x + 1) =$

6.  $(2x + 2)(x + 1) =$

**Divide.**

7.  $(2x^2 + 5x) \div x =$

8.  $(2x^2 + 4x + 2) \div (2x + 2) =$

## Mixed Review Practice 3

Name \_\_\_\_\_

Use your Algebra Tiles™ and Product Mat to complete the following:

**Write the additive inverse.**

1.  $3x^2 + 2x^2 + 4x$

2.  $6x - x + 3$

3.  $x^2 - 3xy + y^2$

**Add or subtract.**

4. 
$$\begin{array}{r} 2x^2 + 2x + 2 \\ + (-x^2 + 3x - 4) \\ \hline \end{array}$$

5. 
$$\begin{array}{r} 2x^2 + 2x + 2 \\ - (-x^2 + 3x - 4) \\ \hline \end{array}$$

**Multiply.**

6.  $(x + 1)(x + 5) =$

7.  $(x + 2)(x + 4) =$

**Divide.**

8.  $(2x^2 + 7x + 6) \div (x + 2) =$

9.  $(3x^2 + 4x + 1) \div (x + 1) =$

## Mixed Review Practice 4

Name \_\_\_\_\_

Use your Algebra Tiles™ and Product Mat and draw tile models to complete the following:

**Write the additive inverse.**

1.  $-5x^2 - y^2$

2.  $4x^2 + xy - 3y^2$

3.  $-x^2 - x^2 + 2$

**Add or subtract.**

4. 
$$\begin{array}{r} x^2 - x - 3 \\ + (3x^2 + 2x - 6) \\ \hline \end{array}$$

5. 
$$\begin{array}{r} x^2 - x - 3 \\ - (-3x^2 + 2x - 6) \\ \hline \end{array}$$

**Multiply.**

6.  $x(2x + 5) =$

7.  $(x + 1)(2x + 2) =$

**Divide.**

8.  $(2x^2 + 4x + 2) \div (2x + 2) =$

9.  $(3x^2 + 13x + 12) \div (x + 3) =$



# Answer Key

## page 5, Modeling Polynomials Worksheet 1

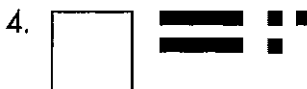
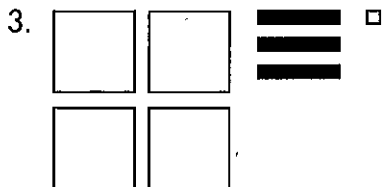

## page 6, Modeling Polynomials Worksheet 2

1.  $-x^2 + 2xy + 2y^2$
2.  $2x^2 - 3xy + 3y^2$
3.  $3x^2 + 4xy - 2y^2$
4.  $-2x^2 + xy + 4y^2$
5.  $3x^2 - 2xy - 3y^2$

## page 8, Modeling Polynomials Worksheet 4

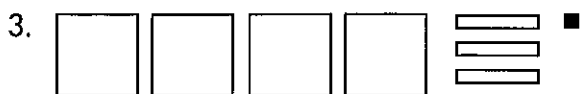

## page 9, Modeling Polynomials Extra Practice



## page 7, Modeling Polynomials Worksheet 3

1.  $2x^2 - 2xy + 3y^2$
2.  $-x^2 + 4xy - y^2$
3.  $2x^2 + 3xy + 3y^2$
4.  $3x^2 - 4xy$
5.  $-2x^2 + xy - 3y^2$

